









# Manual - Fuel Level

## **⚠ WARNING - Please Read Entire Manual Carefully!**

- Do not change settings while driving.
- This product is designed to work with 12 Volt (v) vehicles only! This product will not operate on 6v or 24v systems.
- Please have this product installed by store or dealer where product was purchased. Installation by the customer will void the warranty.
- Do not disassemble or modify this product. Such actions will not only void the warranty, but may also damage or destroy the product.
- Do not perform installations of this product immediately after the engine has been switched off. The engine and exhaust system are extremely hot as this time and can cause burns if touched.

## ➔ Main Features

-  Fuel readout display 0 -100%
-  Onboard memory battery. Gauge will retain settings even after being disconnected from the vehicles battery.
-  High contrast vertical aligned Liquid Crystal Display (LCD), no shadows when backlight is turned off. Different colour values can be chosen for night and day running mode.
-  Warning values can be programmed to trigger a warning busser with 3x different chimes.
-  The warning buzzer can be set 4x different sound levels: Off, low, medium, high.
-  Brightness can be set to 5 different values. For both night and day running mode.
-  3x different movements can be set for indicator display type.
-  Peak values obtained during operation will be stored, this can be reviewed and cleared at a later time (value will remain stored between engine cycles or trips).

## What's Included In Your Kit?

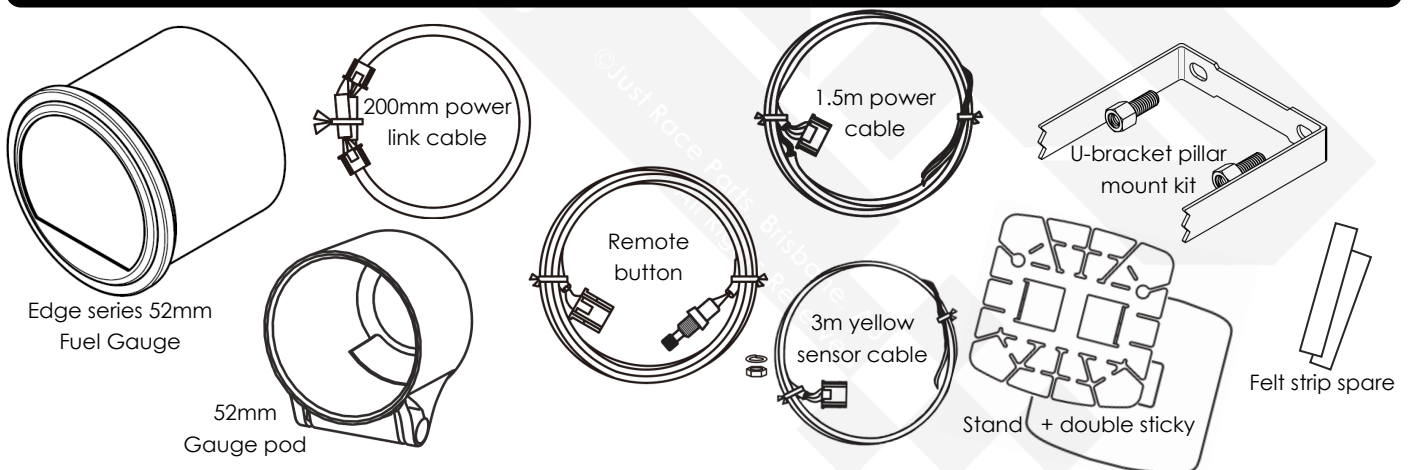

## Gauge Specifications

- Power-supply voltage:  
10v to 15v DC (12v vehicles only)
- Current consumption:  
+B line: MAX 120mA  
IGN line: MAX 120mA  
ILM line: MAX 2mA

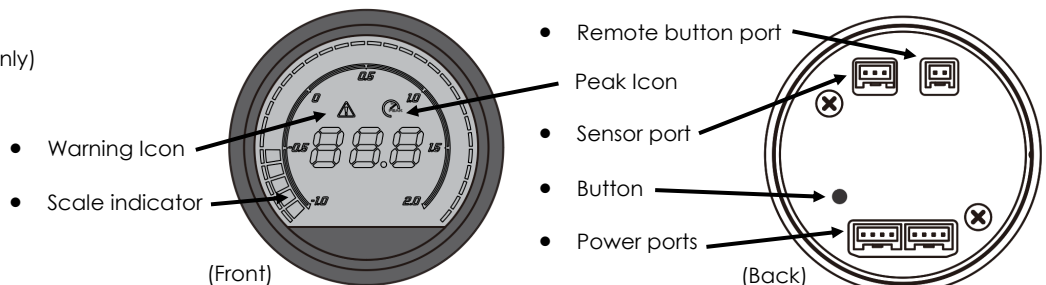

# Manual - Fuel Level

## ⚡ How To Connect Your Wiring

- Disconnect the negative terminal on the battery. Connect the power wires as shown. Warning! Always install a fuse where +12v is indicated.
- Connect the yellow sensor wire to your fuel sender signal wire. (Note: black ground wire should be connected to the fuel sender negative wire - if no ground wire then attach to a metal part of fuel sender unit itself.)
- (Optional) Install remote button wire and connect to the gauge.
- Install 1x felt sticky strip (supplied) on inside edge of gauge pod.
- Reconnect negative battery wire and start using the gauge.

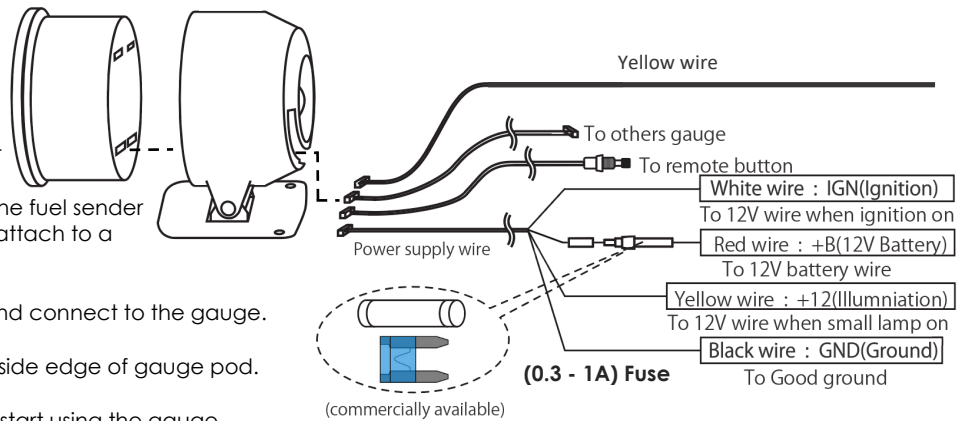

## 🔧 Common Button Operation

- To make changes to your new gauge use the button on the back of the gauge or the remote button included in each kit. (Both provide the same function). The button can be used to scroll through the menu. Short press will take you through the menu options, long press on the displayed option will take you into the setup menu for that selection. Make adjustments to that menu option using short presses, when the setting displays the required value, wait five seconds to return to live data to be display - Saved. (this will confirm and save your set up option). See page 3 for detailed button operation

## 🔍 Fuel Level Sender Calibration Table



FUEL LEVEL SENDER  
24 DIFFERENT  
OHMS SETTINGS



| Number | Sensor Value |
|--------|--------------|
| 1      | 3~100        |
| 2      | 100~3        |
| 3      | 5~120        |
| 4      | 120~5        |
| 5      | 7~200        |
| 6      | 200~7        |
| 7      | 30~300       |
| 8      | 300~30       |
| 9      | 33~566       |
| 10     | 566~33       |
| 11     | 8~98         |
| 12     | 98~8         |

| Number | Sensor Value |
|--------|--------------|
| 13     | 7~108        |
| 14     | 108~7        |
| 15     | 0~190        |
| 16     | 190~0        |
| 17     | 0~90         |
| 18     | 90~0         |
| 19     | 10~73        |
| 20     | 73~10        |
| 21     | 33~240       |
| 22     | 240~33       |
| 23     | 10~180       |
| 24     | 180~10       |

\*Note\* Day and night time modes can be set to display different settings shown in table on page 3. You have to enter the night time mode to make changes to night time menus. (Night mode is triggered from a 12 volt signal input from the yellow power wire).

## 🔍 Determining My Sensor Value

- Remove fuel level sender from fuel tank (take special care not to bend or damage the float arm while doing this).
- Using a multi meter (set to OHMS  $\Omega$ ). Connect both leads to wires on the fuel sender. Carefully move fuel float to the lowest position it can easily move to, (record the value).
- Do the same for the other direction, move float to upper position and record the value. With the two numbers recorded reference fuel level calibration table. (To the left).
- Choose the two numbers closet to the values that you have recorded.
- You will now have your sensor "Number" required for gauge calibration down below.

👉 Handy tip: Write notes on page 3 or circle number on table

## 🔧 Calibrate Gauge To Read Your Fuel Sender

- Please reference the above table when setting up your fuel level gauge. The "sensor value" is usually supplied with aftermarket fuel sensors. If you can't find this information, please read "Determining my sensor value."
- Power up the gauge. After viewing the opening sequence, you will see live data displayed on the gauge as a percentage.  
\*Note: If you see 3 horizontal lines " - - - " your sensor is not connected correctly to the gauge, check your connection and try again.
- Only when reading live data, Long press. Enter the sensor calibration menu. The flashing number shown on the gauge represents the resistance value chosen for the fuel sender. Short press through each option till you select the number that corresponds with the "Ohms" sensor value appropriate for your fuel level sender. Wait for gauge to return to live data - your settings have now been saved.

# Manual - Fuel Level









## Detailed Button Operation

- The table below shows what to expect when navigating your 52mm Edge series Fuel level gauge, this is more or less an on the fly cheat sheet to assist you during setup. Best way to understand all the features and functions is to read this whole instruction manual carefully.
- For further assistance/ trouble shooting please visit our YouTube channel:
- Visit our social platforms for new ideas, and to see our latest products:  
Alternatively send us a cheeky Dm, were here to help! 😊

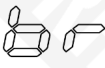
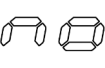
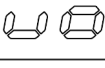

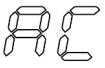
CLICK ICONS TO FOLLOW LINKS

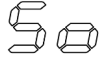
|                              |   |  |                        |                    |
|------------------------------|---|--|------------------------|--------------------|
| <b>LONG PRESS</b>            |    | <b>SHORT PRESS</b> Choose fuel level "number" required for your sensor (See calibration chart page 2).<br>"Symbols blinking"   | <b>LONG PRESS</b>      | Wait 5 sec to save |
| SENSOR CALIBRATION           |   |  |                        |                    |
| <b>SHORT PRESS</b>           |    | Displays the "Peak" value that has recoded in live data.   | <b>LONG PRESS</b>      | Clear peak value   |
| PEAK VALUE                   |   |  |                        |                    |
| <b>SHORT PRESS</b>           |    | <b>LONG PRESS</b> There are two modes for all gauges, night and day mode. Different colours can be set for each mode: Red, Green, Blue, Yellow, Purple, Snow, Mustard, Pink, Light Blue, Orange, Teal, Off, (RGB). | <b>SHORT PRESS</b>     | Wait 5 sec to save |
| COLOUR SELECTION             |   |  | Day Mode<br>Night Mode |                    |
| <b>SHORT PRESS</b>           |   | <b>LONG PRESS</b> There are different brightness settings available to match other instruments in your vehicle. Night and day mode can be set to different levels for each mode.                                   | <b>SHORT PRESS</b>     | Wait 5 sec to save |
| SCREEN BRIGHTNESS            |   |  | Day Mode<br>Night Mode |                    |
| <b>SHORT PRESS</b>           |  | <b>LONG PRESS</b> There are 3 different buzzers available, gauge will display: and emit corresponding sound - Beep: slow, fast, continued...   | <b>SHORT PRESS</b>     | Wait 5 sec to save |
| BUZZER TYPES                 |   |  | Types                  |                    |
| <b>SHORT PRESS</b>           |  | <b>LONG PRESS</b> There are 4 sound levels: Off, 1, 2, 3.<br> Silent to loud  | <b>SHORT PRESS</b>     | Wait 5 sec to save |
| BUZZER VOLUME                |   |  | Level                  |                    |
| <b>SHORT PRESS</b>           |  | <b>LONG PRESS</b> There are 3 options for the opening ceremony, wait for change to be saved and view while turning gauge on/ off.  | <b>SHORT PRESS</b>     | Wait 5 sec to save |
| OPEN/ CLOSE CEREMONIES       |   |  | Types                  |                    |
| <b>SHORT PRESS</b>           |  | <b>LONG PRESS</b> Customise the value to trigger alarm at set value, sort press for fine tune adjustment, long press for rapid number adjustment.  | <b>SHORT PRESS</b>     | Wait 5 sec to save |
| WARNING ALARM                |   |  | Types %                |                    |
| <b>SHORT PRESS</b>           |  | <b>LONG PRESS</b> There are 3 different indicator display types. Its best to view these options when vehicle is up to operating temperature.   | <b>SHORT PRESS</b>     | Wait 5 sec to save |
| SCALE INDICATOR DISPLAY TYPE |   |  | Types                  |                    |

- Record the date of purchase here for warranty purposes \_\_\_\_\_.

Notes: \_\_\_\_\_  
 \_\_\_\_\_  
 \_\_\_\_\_  
 \_\_\_\_\_  
 \_\_\_\_\_