

## ⚠ WARNING - Please Read Entire Manual Carefully!

- Do not change settings while driving.
- This product is designed to work with 12 Volt (v) vehicles only! This product will not operate on 6v or 24v systems.
- Take care reading through this manual, if you're not sure ask JRP via Email/ FB Messenger. For best results professional installation may be required for some components.
- Do not disassemble or modify this product. Such actions will not only void the warranty, but may also damage or destroy the product.
- Do not perform installations of this product immediately after the engine has been switched off. Engine oil and fluid in the cooling system are extremely hot at this time and can cause serious burns if touched.

## ➔ Main Features

- ✨ High quality and accurate Water temperature, Water Detection and (Optional) Oil compatible pressure sensors.
- 📱 Onboard memory battery. Gauge will retain some settings even after being disconnected from the vehicles battery.
- 📺 High contrast vertically aligned Liquid Crystal Display (LCD), no shadows when backlight is turned off. Different colour values can be chosen for night and day running mode.
- ⚠ Warning values can be programmed to trigger a warning buzzer with 3x different chimes. \*Check after battery disconnect\*
- 🔊<sup>2x</sup> Dual warning for 2x warning buzzer can be set 4x different sound levels: Off, low, medium, high. (Read Head Guard Page 2).
- 🌞 Brightness can be set to 5 different values. For both night and day running mode.
- ❤️ 3x different movements can be set for indicator display type.
- 🏠 Peak values obtained during operation will be stored, this can be reviewed and cleared at a later time (value will remain stored between engine cycles or trips).

## 📦 What's Included In Your Kit?

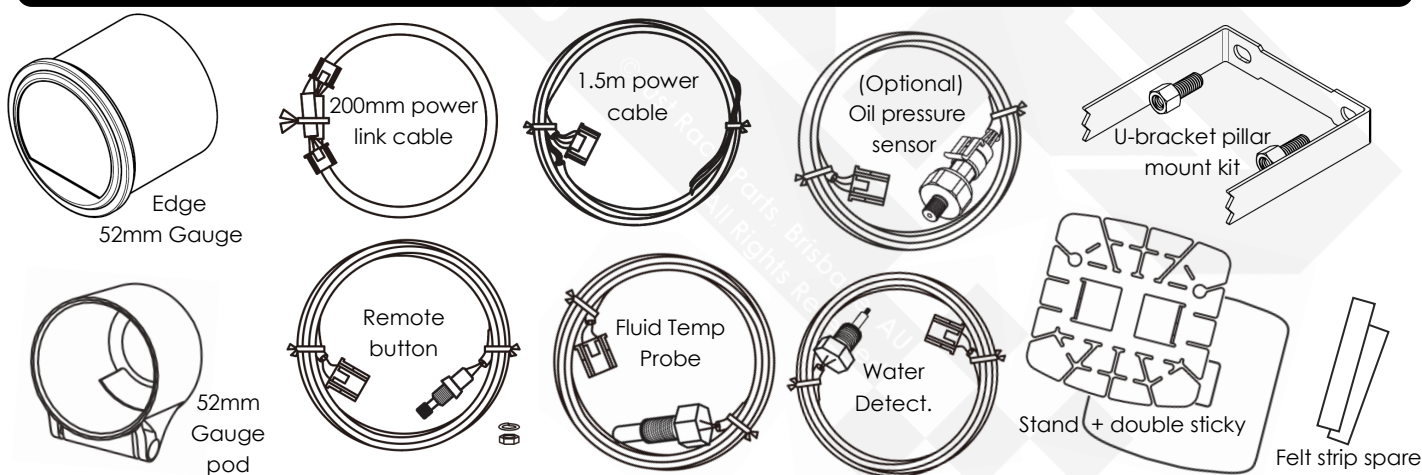

## 📺 Gauge Specifications

- Power-supply voltage: 9v to 17v DC (12v vehicles only)
- Current consumption:  
+B line: MAX 120mA  
IGN line: MAX 120mA  
ILM line: MAX 2mA

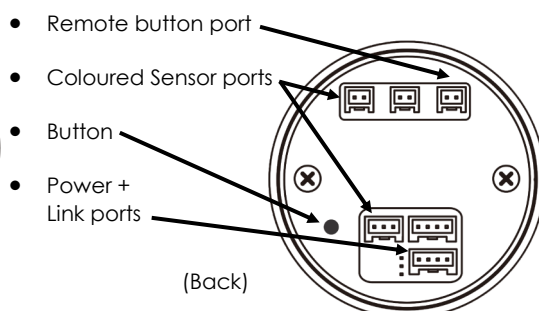
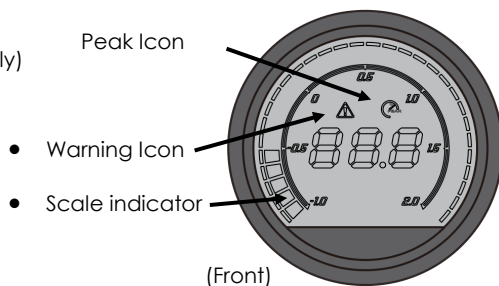

# Manual: Water Temp/ Low Coolant & Oil Press



## ☺ Colour Pre-Warn!



- Colour Pre-warn (CPW) is a new innovation developed first in the world by Just Race Parts! Originally introduced with V1.5 Edge series temperature gauges.

There is a traditional alarm warning which works the same as old/ competitor gauges where you set a warning value that can trigger an alarm on the gauge. And now with the CPW feature enabled; the gauge will change display colours leading up to your set warning alarm.



You can set custom colours as well as the pre-set adjustable number increments.

See example below: **Blue** is your "day mode" running colour, **100c** is your warning alarm trigger value **2** is your temperature control (TC) increment.



Temperature below 94c display colour says to: (Mode set colour)



Temperature above 94c display colour change to: (Yellow default)





Temperature above 96c display colour change to: (Orange default)



Temperature above 98c display colour change to: (Red default)



Temperature above 100c display warning  sound  buzzer alarm

**To enable Colour Pre-Warn:** Navigate to Temperature Control marked as "TC" in the menu. Long press to make changes (OFF is default). The values available for 3in1 Water Temp gauges are 2,5,10.

## 🛡️ New - Head Guard



Head Guard is JRP's latest update to the Edge Series 52mm Gauge line. It's always been obvious for both 4x4 and performance race vehicles that it was critical monitor engine coolant temperatures. Now, that's only half the picture and a clue to a potentially expensive problem...

Water Temperature gauges generally will display reliable data, ONLY if there is fluid in the system.

No water = Bad news for engine, and the temperature gauge reads silly numbers!

So, 2024 brought on the development of detecting water and coolant fluids in the radiator system. This led us to specially develop a water detection sensor that will trigger an alarm on the JRP 3in1 gauge; even if it detects a momentary air pocket in the cooling system. We call this the "Low Coolant Alarm." The low coolant alarm used in conjunction with CPW should alert you to sudden loss of fluid in the cooling system, or even help diagnose potential fluid bleeding issues on coolant flushes.

**Head Guard** is where all this comes together in the perfect 3in1 package! This is an innovative system developed here at JRP to further protect engines. Say for example for whatever reason your coolant level drops below normal operating conditions, the gauge will alert you with the Low Coolant alarm. This can be especially handy for 4x4 guys that do a lot of real serious off-roading! Imagine hitting rocks or a number of things which could penetrate the radiator system and cause a catastrophic loss of coolant in the engine, and there really isn't any kind of factory warning for this. So knowing this has occurred can be the difference between stopping what you are doing and working it out, to not knowing and destroying the head on your engine, which as we all know, equals a lot of money. The aim of Head Guard is to alert you to the fact something has gone very wrong with your engine right away, if you manage to catch a large water leak early you can potentially stop running the engine before causing 2k - \$5k in engine damages... Once you warp a head it's done, and this little feature will help keep you alerted before you see catastrophic failure!

**Activate Head Guards Low coolant** covered in detail on [Page 4](#).

**Dual Warning System: Water Temp + Oil Pressure (Only).** [Page 4](#)

There are 2x alarm chime styles that will alert you to an issue on the gauge.

**SLOW beep** (Default) that will activate when the gauge detects **Low Coolant** or a **High Temperature** event (Exceeding the CPW).

And a second more urgent **FAST beep** alarm for **Low Oil Pressure**. If activated the gauge will flash with the letter "L" just above the pressure units displayed on the gauge.

The alarm buzzer style can be changed via following menus:

**No.** = Low Coolant + High Temperature Buzzer chime.

**No.L** = Low oil Pressure Alarm Buzzer chime.



## Display Configuration/ Gauge Mode (TY Modes)

There are 3x different display modes available for the "3in1 Water Temp + Head Guard 52mm Edge gauge. Think of the "TY" modes as a "running mode" and also a "display style." Each "TY" mode will have a default display for the screen layout, this will also give access to unique alarm modes from this "TY" display style.

While gauge displays live data press and hold the button on the back of the gauge until "TY Number" displays. Next use a short press to change the TY mode, short button press can be used to scroll through the other display modes.

Stop on the desired mode and wait 5 seconds to return to live data. Note: if no number displays, like this: The sensor is not detected in that running mode.

- **TY1** - Will show Oil Pressure **BAR** as a number in the centre, and will monitor Water Temp on the outer scale
- **TY2** - (Default Oil Press) Will show Oil Pressure **PSI** as a number in the centre, and will monitor Water Temp on the outer scale
- **TY3** - Will show the **Water Temp** input in the centre as a number, and will monitor Water Temp on the outer scale



TY1

Oil Pressure BAR  
+ Water Temp



TY2

Oil Pressure PSI + Water Temp  
(Default Oil pressure)



TY3

Water Temp + Water Temp  
(Default Water Temp only + Low coolant)

During the setup process, the gauge must be switched to the display running mode for the connected sensors. This will give access to the alarm set menus for the chosen inputs on the gauge. Once the warning alarms are set: they will remain active and monitor the sensor input in the background regardless of the chosen "display mode." So, you can choose to run the gauge in: TY3 Water temp/ water temp mode, but can also be alerted to a Low coolant condition or a Low Oil Pressure event in your engine 😊

(See more on Page 4 - Warning setup and Display)

## Oil Pressure Detailed (Optional when purchased with Sensor)

**Pressure Warning Setup** will require changes to the default settings. The oil pressure alarm will be turned "OFF" by default.

The oil pressure alarm is different to the water temperature alarm. Water temperature will trigger an alarm if the set value is exceeded, whereas the oil pressure will trigger the alarm only if the pressure drops below the "Set Value."

As part of the setup process navigate through the menu. You will see warning symbol, Oilcan Icon, BAR or PSI units and "OFF." Press and hold, confirmed with a beep, continue with short press until the desired alarm pressure value is displayed on the screen. Wait until the screen returns to live data, and the alarm set value will be saved.

**Alarm Will Not Turn Off** when pressure value drops to zero!

This is a deliberate design feature where if you have a low pressure alarm: the gauge will display a warning all the way down to Zero! The only way to stop this alarm is to turn the engine off. Potentially minimising damage in the process.

Most oil pressure gauges will sound an alarm until about 3 PSI, then go silent. *In the heat of the moment you might think, "Hey cool that alarm is quite now, everything must be ok?... Followed by, "BANG!"*

Just Race Parts has implemented this as a point of difference compared to the rest of the 52mm gauge market, and is just another little innovation that brings enormous value to JRP customers.

**Hush Oil Pressure Alarm** can be done by interrupting the "white ignition trigger wire" either by turning off the ignition to the car.

Or, for race cars: you may want to add a mechanical switch to the ignition wire that is "PUSH TO OFF." This is a special switch that is normally closed switch with continuity between the 2 terminals. Pressing the button breaks the continuity between the switch terminals. Press links for Australian retailers that stock this switch: [Jaycar Listing](#) OR [Core Electronics listing](#).

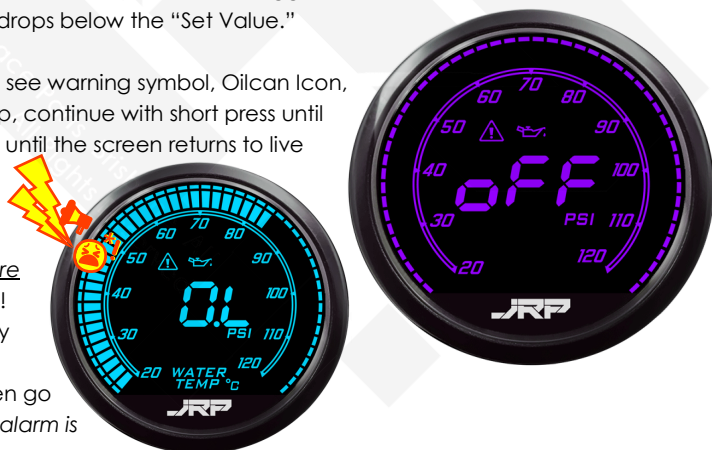



## Peak Value/ Combo Gauges

Peak menu operates differently on 3in1 Edge gauges compared with single sensor gauges. The Gauge will cycle through the all peak values that alarms are set for. All values can be cleared from any peak menu: Press and hold to enter peak menu: Up to 3x different values with corresponding Icon will cycle though. Press & hold at any time and values will be cleared Confirmed with 3x Dash " - - - " no need to clear if you wish to keep peak values in memory, However it's best to clear the peak values so that you can see your new all time high score next time you're pushing the limits!

(Peak values: Temperature, Low Pressure PSI or BAR Values).

**Oil Pressure always showing peak value as zero:** You will need to clear your peak values while the engine is running. The gauge will be monitoring pressures after opening sequence, Oil pressure should be high when cold. Check the wiring of the gauge as your settings won't save after total power loss on the red wire detailed on [Page 5](#). Pressure must have warning set for peak numbers to recorded (OFF default).



## Warning Set Up & Alarm Displays

Alarm monitoring and displays styles are a little bit different on the 3in1 Water temp Gauge when compared to Single alarm Edge gauges. Animation styles are improved with synchronised "Beep" tone, and the addition of custom animations with each beep style. "This can be handy if you decide to turn off the audible alarm, there will still be 3x different animations to choose from on the display."

Alarms are a very important function to JRP Edge gauges, its important to read and understand this section well as some pretty sophisticated ideas have been condensed into a simple menu setup. **This section is seriously worth the read!**

**Alarm Events:** Briefly mentioned in the "Display mode section," the Gauge needs to change "TY" Display mode to access some alarm setup menus. Temperature and Low Coolant Alarms can be modified from all display modes, However, Oil Pressure "alarms & calibration" can only be accessed in their respective modes: TY1 (BAR) & TY2 (PSI).

**Alarms monitor All Sensors** connected to the gauge. Once the alarm is set for Oil pressure in this display mode it will automatically turn off other Oil pressure alarms **E.g.** The gauge can be left to run in TY2 running mode if you wish to see Oil Press. PSI number value at all times. You can however, configure the gauge to display in another mode, (Water Temp & Oil Pressure BAR).

When the gauge sees a condition where the Oil Pressure PSI value has dropped below the alarm set value - the screen will temporarily change the centre number back to PSI and display the number till the alarm event is over.

Detailed in "[After Warning Flash](#)" **bottom of page.**

**Unexpected PSI & BAR Alarms** can occur if warning is set in one of the pressure modes then the Display mode is changed to alternative units. **E.g.** Alarm is set in "TY2 PSI MODE" then the display mode is changed to "TY1 BAR MODE" Pressure numbers will display in BAR. However, when the alarm is activated Pressure number will still display in PSI units (PSI Symbol will be active).

To resolve: You must set a new alarm value in BAR while the gauge is in TY1 running mode. The PSI Alarm will Auto switch to: **OFF**



**Low Oil Pressure Alarm** should be set up using the concepts detailed on [pages 2-3](#).

The pressure warning alarm will need to be set to a warning value before it will trigger (Default is **OFF**). If the Low oil pressure alarm is triggered the gauge will beep fast and display the pressure value E.g.: "12.L PSI" Beep style type for the pressure alarm can be changed in the "**No.L**" menu and should be set differently to the other alarms.

**Notice:** No.L will override all other active alarm tones when activated.

"Coolant and Temperature" alarms both use same beep style. Change this beep style with menu option "**No.**"

**\*Low Coolant Alarm** will not be active from first time the gauge is powered up. Its recommended to change the setting to 0 (Zero) & have the alarm active as soon as water isn't touching the probe. Low coolant alarm can be changed to different delay numbers depending on the sensor install location and what the vehicle is doing. High G-force or coolant slosh may trigger false alarms, so adjust as necessary.

**Low Coolant settings** are: OFF, 0sec, 5sec, 10sec, 20sec, and can be changed in the "**Lc**" menu.

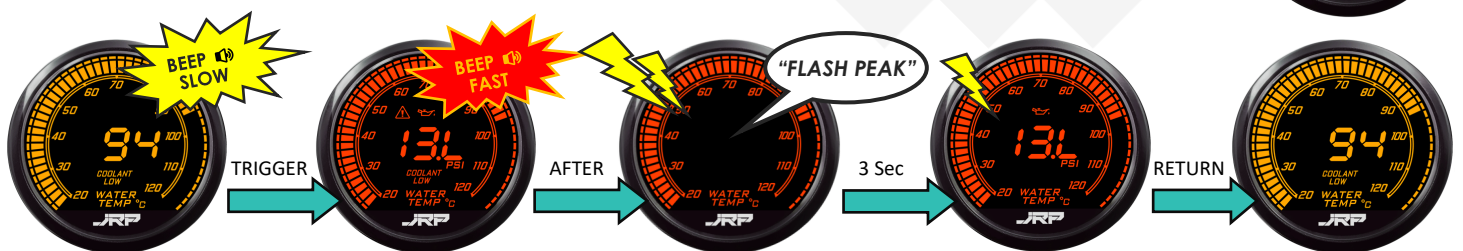

**After Warning Flash:** occurs when a display change was required to show a background warning alarm not in current display mode. Once alarm is no longer required the "PEAK Value" will **"Flash 3 seconds"** before returning back to live data from set running mode. Pictured Example: Display mode "TY3 Water Temperature only (Slow beep) for Low Coolant alarm. Value has Dropped below Pressure alarm set: Number changes from Water temp to Low oil pressure (Fast Beep). After Pressure warning complete the "PSI PEAK Number" will flash 3sec before returning to the Water Temperature display number.



## ⚡ How To Connect Your Wiring

Test your gauge in isolation before adding it to your vehicle's power system. Black wire: To the Negative ( - ) terminal of the battery  
Red wire & White: To the Positive ( + ) terminal of the battery, after gauge has booted, disconnect and install as below.

- Disconnect the negative terminal on the battery. Connect the power wires as shown. Warning! Always install a fuse where +12v is indicated.
- Connect the supplied sensor wires to their respective harnesses. Follow procedures through manual for sensor specific installation.
- (Optional) install "Hush button" in series with white wire
- (Optional) Install remote button wire and connect to the gauge
- Install 1x felt sticky strip if required (included) on inside edge of pod
- Reconnect negative battery wire and start using the gauge

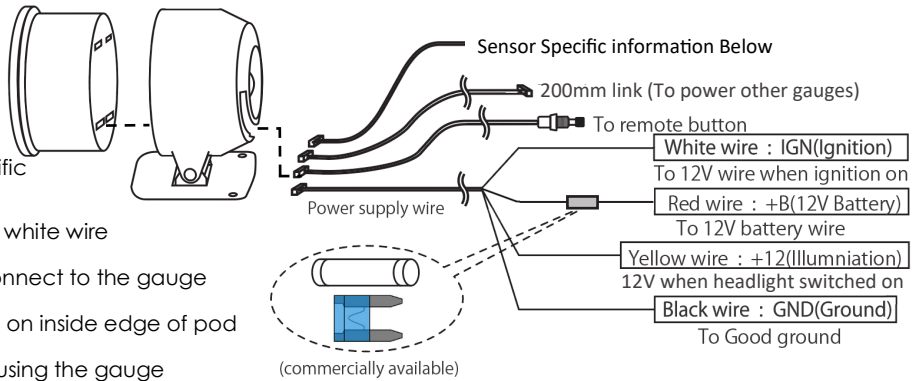

## 🌊 Install Water Sensors

**WARNING:** It's highly important to run an independent ground wire from the hose adapter to the either the negative terminal of the battery or to a clean ground point on a negatively charged chassis. Also critical for reliable engine monitoring and long-term sensor life that: High quality, and clean engine coolant/ anti-freeze is used in your vehicles radiator cooling system. Water alone will not only damage the entire cooling system with corrosion, but this will also lead to premature sensor failure.

**For easy sensor installations:** Use the JRP 3in1 Radiator hose adapter kit. Please ensure that you purchase the correct size to suit your cooling system hose diameter. Radiator hoses are designed to work under pressure and will not stretch to incorrectly sized spout ends. You can check hose size with your local auto parts supply store, or measure the diameter of an exposed spout on the cooling system. (Ask JRP Sales team we're here to help!) 😊

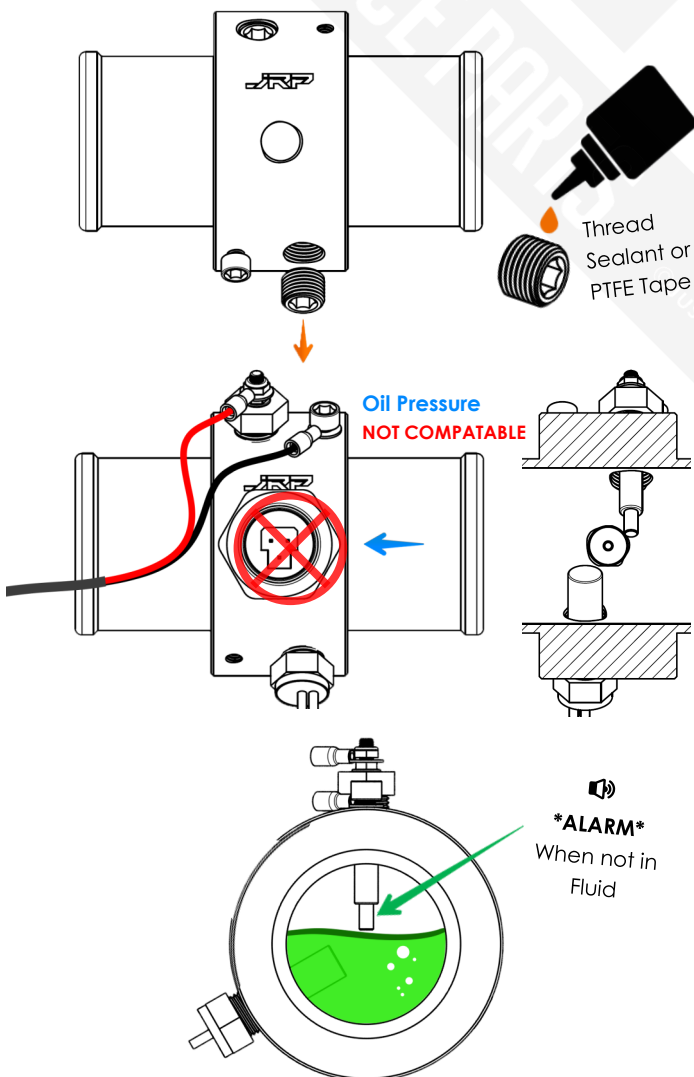

**1/8 Threaded holes are tapered and don't need to be over tightened. JRP adapters are supplied loosely assembled. CHECK & Install all fittings finger tight to verify fitment in vehicle before final installation. WARNING Anodised coating: may need to be removed on inside face of hose adapter Low coolant circuit to complete. (Only if false alarms are present).**

1. For final installation, remove grub screws and sensors. You must apply high temperature thread sealant or PTFE Tape on All 1/8 NPT threads on the male fittings.

2. Sensors should be finger tight, Then 1-2 turns firm. (7in-Lbs/ 0.79Nm). Follow directions recommended on tread sealing method for best results.

3.\*Centre port (Blue Arrow). Oil pressure sensor will not work here sensor is designed for Oil and will fail when exposed to water. Oil sensor install page 6. Its important to install the sensors so that probe tips have no chance of colliding in the hose adapter.

**Wires:** should be secured so that they do not have harsh kinks at the termination point. Cable tie and run parallel to radiator hose.

🧠 **Handy Tip:** Expandable braided cable sleeve.

Corrugated conduit or spiral sleeve should be used to cable manage and group the sensor cables together.

4. Install separate ground wire as mentioned in warning above!

Low coolant sensor should be installed so that the Chrome tip is at the highest point in the fluid stream. Air pockets are more likely to develop at the highest point in the cooling system. Depending on your hose diameter you may need to mount the Low Coolant Sensor upside down?

**Sensor Reference below:**



## 🔧 Install Oil Pressure Sensor

**WARNING:** Oil pressure sensor included in this kit (Optional) is designed to work only with engine oil in clean petrol/ diesel applications. This sensor will fail in the presence of Ethanol/ Methanol based fuels. If your engine uses these as part of their fuel source your engine oil will become contaminated with these fluids and damage the sensor. Customers using these fluids can purchase an e85 sensor from JRP that can handle the nature of these fluids. (Oil Pressure sensor will fail if installed in cooling system, voiding your warranty).

Customers that need water pressure should buy the JRP 3in1 Water Temp + Water Pressure Gauge with Headguard Ultra.

**Handy tip:** Sensor adapter blocks or sandwich plate adaptors can be used to avoid permeant modifications to your engine.

Oil cooler kits can also be installed off an adapter plate available with other aftermarket kits.

Alternatively there are other methods to mount these pressure sensors, consult a qualified mechanic, or research DIY solutions online. **DO NOT USE BRASS FITTINGS** with oil pressure sensors! Brass is extremely brittle & can fail unexpectedly with normal engine vibrations. This is usually found on cheap tee adapters. Stainless steel or Aluminium Tee adapters are recommended instead.

JRP oil pressure sensors are of high quality and rarely fail, if installed correctly. Take care not to drop sensors on hard surface during installation as this may cause premature wear/ damage to sensor.

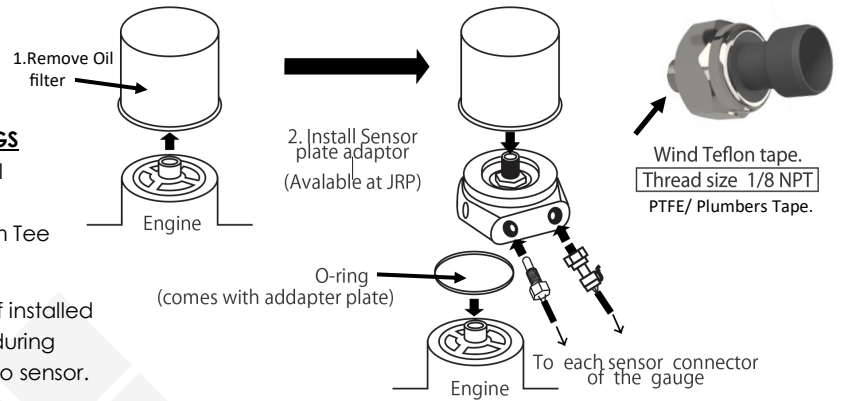

## 🔔 Common Button Operation

- To make changes to your new gauge use the button on the back of the gauge or the remote button included in each kit. (Both provide the same function). The button can be used to scroll through the menu. Short press will take you through the menu options, long press for three seconds on the displayed option will take you into the setup menu for that selection. Make adjustments to that menu option using short presses, when the setting displays the required value, wait five seconds to return to live data to be display - Saved. (this will confirm and save your set up option). See page 3 & 4 for detailed button operation.
- Day and Night Modes** can be set to display different settings shown in table below. You have to enter the night time mode to make changes to night time menus. (Night mode is triggered from a 12 volt signal input from the yellow power wire).

## 🔧 Temperature Warm-up

- Colour Slowly Fades** when temperature warmup is enabled. This warmup function works only when temperature is below set value in the "UP Menu." *Selectable options are: OFF, 40, 60, 80.*

When enabled this feature will fade cycle the first colour from (CL1) and current display mode colour Day/ Night mode. This is just a really passive warning function intended to show the driver that you should take it easy on the vehicle till you're in the operating temperature range. Make changes to this function navigate to the "UP" menu. **Handy Tip:** If the gauge has an **intermittent warning symbol** but no alarm this setting may be active. Change "UP" setting to off and see if this resolves the issue. Check that the CL1 colour is set to yellow and not the same as your normal running colour.



## 🔔 Detailed Button Operation

- The tables on the following pages shows what to expect when navigating your 52mm 3in1 Edge series gauge, this is more or less an on the fly cheat sheet to assist you during setup. Best way to understand all the features and functions is to read this whole instruction manual carefully.

- For further assistance/ trouble shooting please visit our YouTube channel:

- Visit our social platforms for new ideas, and to see our latest products:

Alternatively send us a cheeky Dm, we're here to help! 😊

- Record the date of purchase here for warranty purposes \_\_\_\_\_.

Notes: \_\_\_\_\_  
 \_\_\_\_\_  
 \_\_\_\_\_  
 \_\_\_\_\_

## Detailed Button Operation TY1 Water Temp/ Oil Pressure BAR

TY1 - Water Temp/ Oil Pressure BAR		
<b>LONG PRESS</b> GAUGE MODE CONFIGURATION	See "Display Configuration" for in depth explanation on Page 3. HINT: below Each TY# value shows: Water Temp, BAR, PSI. This will change numerical value centre of screen.	<b>SHORT PRESS</b> tY1 ▶ tY2 ▶ tY3
<b>SHORT PRESS</b> PEAK VALUE	<b>LONG PRESS</b> Displays cycles "Peak" value twice on screen. NOTE: Peak values are only recorded if alarm is set to monitor that input. (Peak icon flash when in menu)	<b>LONG PRESS</b> Clear peak value CONFIRM "- . - ."
<b>SHORT PRESS</b> COLOUR SELECTION	<b>LONG PRESS</b> There are two modes for all gauges, night and day mode. Different colours can be set for each mode: Red, Green, Blue, Yellow, Purple, Snow, Mustard, Pink, Light Blue, Orange, Teal, Off, (RGB).	<b>SHORT PRESS</b> Day Mode <b>Short Press</b> Night Mode Wait 5 sec to save
<b>SHORT PRESS</b> SCREEN BRIGHTNESS	<b>LONG PRESS</b> There are different brightness settings available to match other instruments in your vehicle. Night and day mode can be set to different levels for each mode.	<b>SHORT PRESS</b> Day Mode <b>Short Press</b> Night Mode Wait 5 sec to save
<b>SHORT PRESS</b> BUZZER STYLE	<b>LONG PRESS</b> There are 3 different buzzers available, gauge will display: and emit corresponding sound - Beep: slow, fast, continued...	<b>SHORT PRESS</b> Default: Slow Beep no0 ▶ no1 ▶ no2 Wait 5 sec to save
<b>SHORT PRESS</b> BUZZER VOLUME	<b>LONG PRESS</b> There are 4 sound levels: Off, 1, 2, 3. Silent to loud	<b>SHORT PRESS</b> Level uo0 ▶ uo1 ▶ uo2 ▶ uo3 Wait 5 sec to save
<b>SHORT PRESS</b> OPEN/ CLOSE CEREMONIES	<b>LONG PRESS</b> There are 3 options for the opening ceremony, wait for change to be saved and view while turning gauge on/off.	<b>SHORT PRESS</b> Types AC1 ▶ AC2 ▶ AC3 Wait 5 sec to save
<b>SHORT PRESS</b> BAR LOW PRESSURE WARNING	<b>LONG PRESS</b> Customise the BAR pressure value to trigger alarm. Short press for fine tune adjustment, long press for rapid number adjustments.	<b>SHORT PRESS</b> BAR Value OFF-0.9BAR to 3.1BAR Wait 5 sec to save
<b>SHORT PRESS</b> Water TEMP WARNING	<b>LONG PRESS</b> Customise the Water temperature value to trigger alarm. Short press for fine tune adjustment, long press for rapid number adjustments.	<b>SHORT PRESS</b> EGT Value 20c to 120c Wait 5 sec to save
<b>SHORT PRESS</b> BAR OFFSET CALIBRATION	<b>LONG PRESS</b> Fine tune adjustment for BAR pressure offset, aim for 0.00 BAR when engine not running. You will need to repeat short press of button till display reads 0.00BAR	<b>SHORT PRESS</b> BAR Value (PSI Equivalent) -0.6 to 0.6BAR -8.7 to 8.7PSI Wait 5 sec to save
<b>SHORT PRESS</b> PRESSURE BUZZER STYLE	<b>LONG PRESS</b> There are 3 different buzzers available for high pressure alarm, gauge will display warning: and emit corresponding sound - Beep: slow, fast, continued...	<b>SHORT PRESS</b> Default: Fast Beep noL ▶ n1L ▶ n2L Wait 5 sec to save
<b>SHORT PRESS</b> SCALE INDICATOR	<b>LONG PRESS</b> There are 3 different indicator display types. This setting will change how the outer scale displays increments. It's best to view these options when the vehicle is up to operating temperature.	<b>SHORT PRESS</b> So1 ▶ So2 ▶ So3 ▶ Wait 5 sec to save
<b>SHORT PRESS</b> COLOUR TWO (CPW)	<b>LONG PRESS</b> This is where you set the first colour of the temperature controlled colour pre-warn (CPW) (YELLOW DEFAULT)	<b>SHORT PRESS</b> Leading Up to Warning Alarm Wait 5 sec to save
<b>SHORT PRESS</b> COLOUR THREE (CPW)	<b>LONG PRESS</b> This is where you set the second colour of the temperature controlled colour pre-warn (CPW) (ORANGE DEFAULT)	<b>SHORT PRESS</b> Leading Up to Warning Alarm Wait 5 sec to save
<b>SHORT PRESS</b> COLOUR FOUR (CPW)	<b>LONG PRESS</b> This is where you set the third colour of the temperature controlled colour pre-warn (CPW) (RED DEFAULT)	<b>SHORT PRESS</b> Leading Up to Warning Alarm Wait 5 sec to save
<b>SHORT PRESS</b> WARM UP	<b>LONG PRESS</b> This is where you can set the warm-up function, settings are: Off, 40, 60 & 80. Colour will fade and change between running colour and CL2. Warning icon flash intermittently. (Detailed on page 6).	<b>SHORT PRESS</b> Temperature Range OFF ▶ 40 ▶ 60 ▶ 80 Wait 5 sec to save
<b>SHORT PRESS</b> TEMPERATURE CONTROL	<b>LONG PRESS</b> This is where you can set the colour pre warn function, settings are: Off, 2, 5, & 10 for Water Temperature.	<b>SHORT PRESS</b> Temperature Range OFF ▶ 2 ▶ 5 ▶ 10 Wait 5 sec to save
<b>SHORT PRESS</b> LOW COOLANT ALARM	<b>LONG PRESS</b> This is where you can set the Low coolant alarm, settings are: Off, 0Sec, 5Sec, 10Sec, 20Sec.	<b>SHORT PRESS</b> Temperature Range OFF ▶ 0 ▶ 5 ▶ 10 ▶ 20 Wait 5 sec to save



## Detailed Button Operation (TY2 Water Temp/ Oil Pressure PSI)

TY2 - Water Temp/ Oil Pressure PSI		
<b>LONG PRESS</b> GAUGE MODE CONFIGURATION  /  "Icons blinking"	See "Display Configuration" for in depth explanation on Page 3. HINT: below Each TY# value shows: Water Temp, BAR, PSI. This will change numerical value centre of screen.	<b>SHORT PRESS</b> tY3 tY4 tY5 Wait 5 sec to save
<b>SHORT PRESS</b> PEAK VALUE	<b>LONG PRESS</b> Displays cycles "Peak" value twice on screen. NOTE: Peak values are only recorded if alarm is set to monitor that input. (Peak icon flash when in menu)	<b>LONG PRESS</b> Clear peak value CONFIRM "- - -"
<b>SHORT PRESS</b> COLOUR SELECTION	<b>LONG PRESS</b> There are two modes for all gauges, night and day mode. Different colours can be set for each mode: Red, Green, Blue, Yellow, Purple, Snow, Mustard, Pink, Light Blue, Orange, Teal, Off, (RGB).	<b>SHORT PRESS</b> Day Mode <b>Short Press</b> Night Mode Wait 5 sec to save
<b>SHORT PRESS</b> SCREEN BRIGHTNESS	<b>LONG PRESS</b> There are different brightness settings available to match other instruments in your vehicle. Night and day mode can be set to different levels for each mode.	<b>SHORT PRESS</b> Day Mode <b>Short Press</b> Night Mode Wait 5 sec to save
<b>SHORT PRESS</b> BUZZER STYLE	<b>LONG PRESS</b> There are 3 different buzzers available, gauge will display; and emit corresponding sound - Beep: slow, fast, continued...	<b>SHORT PRESS</b> Default: Slow Beep Wait 5 sec to save
<b>SHORT PRESS</b> BUZZER VOLUME	<b>LONG PRESS</b> There are 4 sound levels: Off, 1, 2, 3. Silent to loud	<b>SHORT PRESS</b> Level Wait 5 sec to save
<b>SHORT PRESS</b> OPEN/ CLOSE CEREMONIES	<b>LONG PRESS</b> There are 3 options for the opening ceremony, wait for change to be saved and view while turning gauge on/off.	<b>SHORT PRESS</b> Types Wait 5 sec to save
<b>SHORT PRESS</b> PSI LOW PRESSURE WARNING  & PSI	<b>LONG PRESS</b> Customise the PSI pressure value to trigger alarm. Short press for fine tune adjustment, long press for rapid number adjustments.	<b>SHORT PRESS</b> PSI Value OFF 0 PSI to 45 PSI Wait 5 sec to save
<b>SHORT PRESS</b> Water TEMP WARNING  & TEMP	<b>LONG PRESS</b> Customise the Water temperature value to trigger alarm. Short press for fine tune adjustment, long press for rapid number adjustments.	<b>SHORT PRESS</b> EGT Value 20c to 120c Wait 5 sec to save
<b>SHORT PRESS</b> PSI OFFSET CALIBRATION  /PSI	<b>LONG PRESS</b> Fine tune adjustment for PSI pressure offset, aim for 0.0 PSI when engine not running. "Icons blinking" You will need to repeat short press of button till display reads 0.0PSI	<b>SHORT PRESS</b> PSI Value (BAR Equivalent) -9 to 9PSI -0.62 to 0.62BAR Wait 5 sec to save
<b>SHORT PRESS</b> PRESSURE BUZZER STYLE	<b>LONG PRESS</b> There are 3 different buzzers available for high pressure alarm, gauge will display warning; and emit corresponding sound - Beep: slow, fast, continued...	<b>SHORT PRESS</b> Default: Fast Beep Wait 5 sec to save
<b>SHORT PRESS</b> SCALE INDICATOR	<b>LONG PRESS</b> There are 3 different indicator display types. This setting will change how the outer scale displays increments. It's best to view these options when the vehicle is up to operating temperature.	<b>SHORT PRESS</b> Wait 5 sec to save
<b>SHORT PRESS</b> COLOUR TWO (CPW)	<b>LONG PRESS</b> This is where you set the first colour of the temperature controlled colour pre-warn (CPW) (YELLOW DEFAULT)	<b>SHORT PRESS</b> Leading Up to Warning Alarm Wait 5 sec to save
<b>SHORT PRESS</b> COLOUR THREE (CPW)	<b>LONG PRESS</b> This is where you set the Second colour of the temperature controlled colour pre-warn (CPW) (ORANGE DEFAULT)	<b>SHORT PRESS</b> Leading Up to Warning Alarm Wait 5 sec to save
<b>SHORT PRESS</b> COLOUR FOUR (CPW)	<b>LONG PRESS</b> This is where you set the third colour of the temperature controlled colour pre-warn (CPW) (RED DEFAULT)	<b>SHORT PRESS</b> Leading Up to Warning Alarm Wait 5 sec to save
<b>SHORT PRESS</b> WARM UP	<b>LONG PRESS</b> This is where you can set the warm-up function, settings are: off, 40, 60 & 80. Colour will fade and change between running colour and CL2. Warning icon flash intermittently. (Detailed on page 6).	<b>SHORT PRESS</b> Temperature Range OFF t40 t60 t80 Wait 5 sec to save
<b>SHORT PRESS</b> TEMPERATURE CONTROL	<b>LONG PRESS</b> This is where you can set the colour pre warn function, settings are: Off, 2, 5, & 10 for Water Temperature.	<b>SHORT PRESS</b> Temperature Range OFF t2 t5 t10 Wait 5 sec to save
<b>SHORT PRESS</b> LOW COOLANT ALARM	<b>LONG PRESS</b> This is where you can set the Low coolant alarm, settings are: Off, 0Sec, 5Sec, 10Sec, 20Sec.	<b>SHORT PRESS</b> Temperature Range OFF t0 t5 t10 t20 Wait 5 sec to save

## Detailed Button Operation (TY5 PSI/ Water Temp)

TY3 - Water Temp + Low Coolant		
<b>LONG PRESS</b> GAUGE MODE CONFIGURATION  /  "Icons blinking"	See "Display Configuration" for in depth explanation on Page 3. HINT: below Each TY# value shows: Water Temp, BAR, PSI. This will change numerical value centre of screen.	<b>SHORT PRESS</b> TY3 ▶ TY4 ▶ TY5 Wait 5 sec to save
<b>SHORT PRESS</b> PEAK VALUE	<b>LONG PRESS</b> Displays cycles "Peak" value twice on screen. NOTE: Peak values are only recorded if alarm is set to monitor that input. (Peak icon flash when in menu)	<b>LONG PRESS</b> Clear peak value CONFIRM "- - -" Wait 5 sec to save
<b>SHORT PRESS</b> COLOUR SELECTION	<b>LONG PRESS</b> There are two modes for all gauges, night and day mode. Different colours can be set for each mode: Red, Green, Blue, Yellow, Purple, Snow, Mustard, Pink, Light Blue, Orange, Teal, Off, (RGB).	<b>SHORT PRESS</b> Day Mode <b>Short Press</b> Night Mode Wait 5 sec to save
<b>SHORT PRESS</b> SCREEN BRIGHTNESS	<b>LONG PRESS</b> There are different brightness settings available to match other instruments in your vehicle. Night and day mode can be set to different levels for each mode.	<b>SHORT PRESS</b> Day Mode <b>Short Press</b> Night Mode Wait 5 sec to save
<b>SHORT PRESS</b> BUZZER STYLE	<b>LONG PRESS</b> There are 3 different buzzers available, gauge will display: and emit corresponding sound - Beep: slow, fast, continued...	<b>SHORT PRESS</b> Default: Slow Beep Wait 5 sec to save
<b>SHORT PRESS</b> BUZZER VOLUME	<b>LONG PRESS</b> There are 4 sound levels: Off, 1, 2, 3.  Silent to loud	<b>SHORT PRESS</b> Level Wait 5 sec to save
<b>SHORT PRESS</b> OPEN/ CLOSE CEREMONIES	<b>LONG PRESS</b> There are 3 options for the opening ceremony, wait for change to be saved and view while turning gauge on/off.	<b>SHORT PRESS</b> Types Wait 5 sec to save
<b>SHORT PRESS</b> Water TEMP WARNING  & TEMP	<b>LONG PRESS</b> Customise the Water temperature value to trigger alarm. Short press for fine tune adjustment, long press for rapid number adjustments. "Icons solid"	<b>SHORT PRESS</b> EGT Value 20c to 120c Wait 5 sec to save
<b>SHORT PRESS</b> SCALE INDICATOR	<b>LONG PRESS</b> There are 3 different indicator display types. This setting will change how the outer scale displays increments. It's best to view these options when the vehicle is up to operating temperature.	<b>SHORT PRESS</b> Wait 5 sec to save
<b>SHORT PRESS</b> COLOUR TWO (CPW)	<b>LONG PRESS</b> This is where you set the first colour of the temperature controlled colour pre-warn (CPW)  (YELLOW DEFAULT)	<b>SHORT PRESS</b> Leading Up to Warning Alarm Wait 5 sec to save
<b>SHORT PRESS</b> COLOUR THREE (CPW)	<b>LONG PRESS</b> This is where you set the second colour of the temperature controlled colour pre-warn (CPW)  (ORANGE DEFAULT)	<b>SHORT PRESS</b> Leading Up to Warning Alarm Wait 5 sec to save
<b>SHORT PRESS</b> COLOUR FOUR (CPW)	<b>LONG PRESS</b> This is where you set the third colour of the temperature controlled colour pre-warn (CPW)  (RED DEFAULT)	<b>SHORT PRESS</b> Leading Up to Warning Alarm Wait 5 sec to save
<b>SHORT PRESS</b> WARM UP	<b>LONG PRESS</b> This is where you can set the warm-up function, settings are: off, 40, 60 & 80. Colour will fade and change between running colour and CL2. Warning icon flash intermittently. (Detailed on page 6).	<b>SHORT PRESS</b> Temperature Range OFF ▶ 40 ▶ 60 ▶ 80 Wait 5 sec to save
<b>SHORT PRESS</b> TEMPERATURE CONTROL	<b>LONG PRESS</b> This is where you can set the colour pre warn function, settings are: Off, 2, 5, & 10 for Water Temperature.	<b>SHORT PRESS</b> Temperature Range OFF ▶ 2 ▶ 5 ▶ 10 Wait 5 sec to save
<b>SHORT PRESS</b> LOW COOLANT ALARM	<b>LONG PRESS</b> This is where you can set the Low coolant alarm, settings are: Off, 0Sec, 5Sec, 10Sec, 20Sec.	<b>SHORT PRESS</b> Temperature Range OFF ▶ 0 ▶ 5 ▶ 10 ▶ 20 Wait 5 sec to save